

**FREESTANDING STRUCTURE**

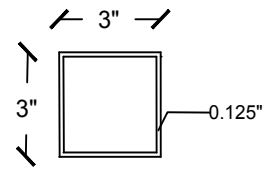

1

**3" X 3" Post**

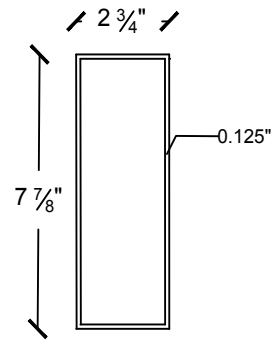

2

**3" X 8" Beam**

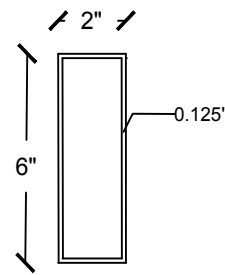

3

**2" X 6" Rafter**

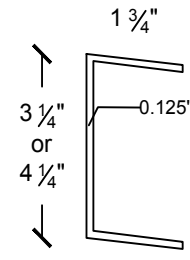

4

**Header**

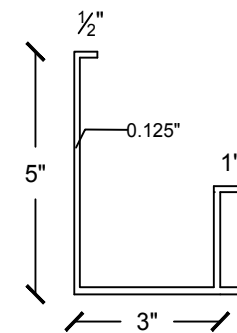

5

**E-Gutter**

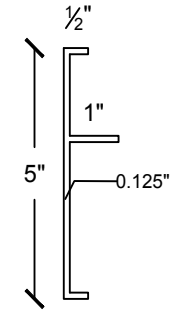

6

**Fascia**

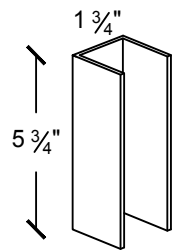

7

**Receiving Channel**

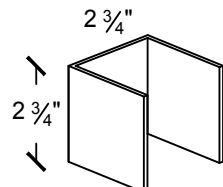

8

**Post "C" Channel**

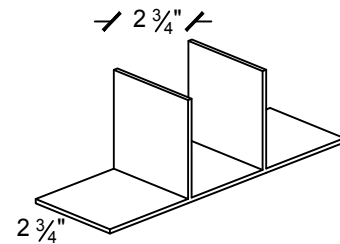

9

**Post Bracket**

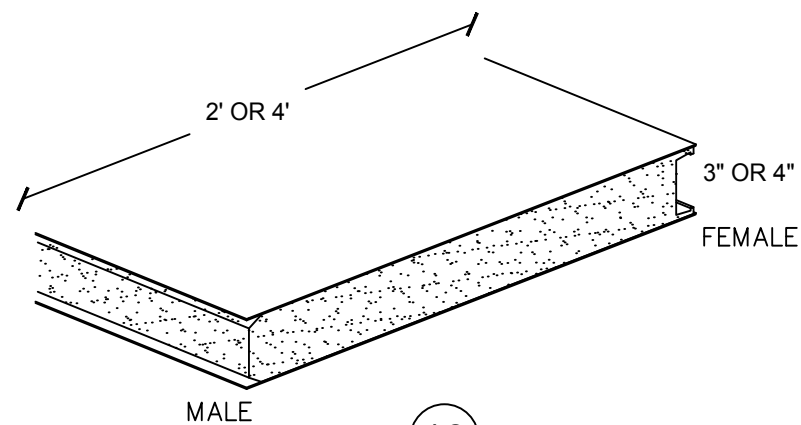

10

**Insulated Aluminum Panel**

**Rafter Ends**

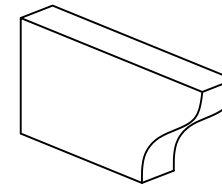

**Scalloped**

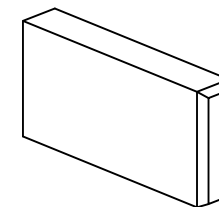

**Beveled**

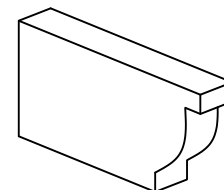

**Corbel**

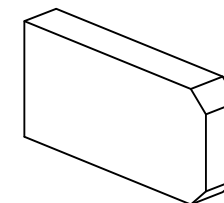

**Mitered**

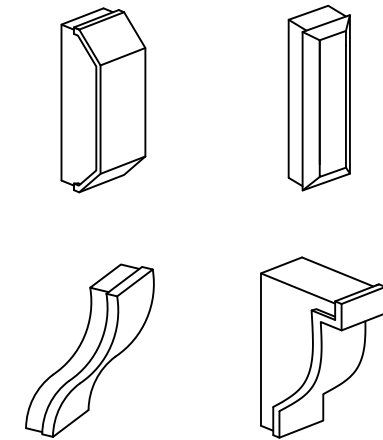

**End Caps**

**COMPONENTS**

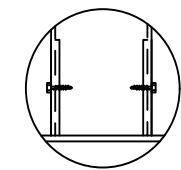
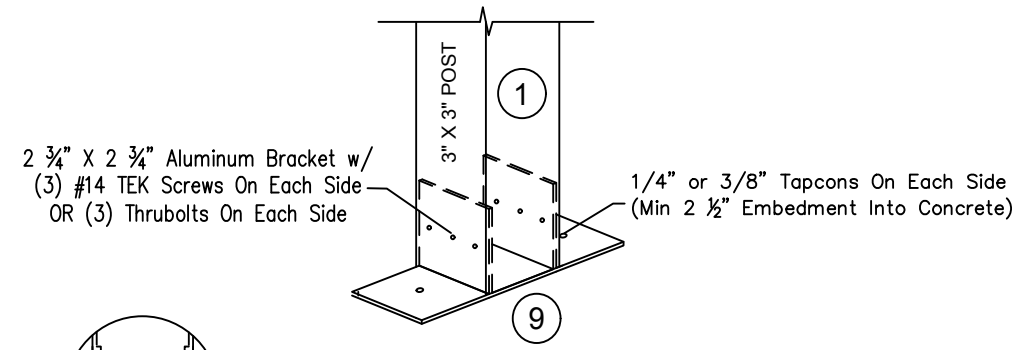

#14 TEK Screws

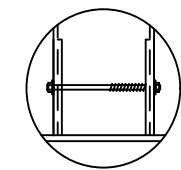

1/4" or 3/8" ThruBolts

CONCRETE SLAB OR FOOTING (PER SITE SPECIFIC ENGINEERING)

**POST ATTACHMENT (ATTACHED)**

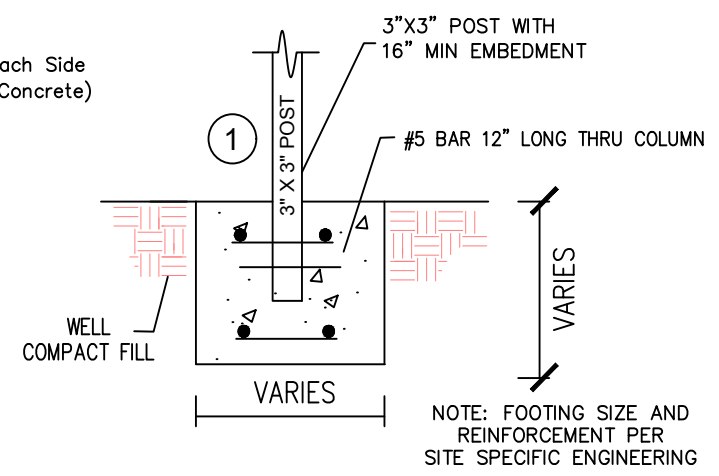

**POST ATTACHMENT (FREESTANDING)**

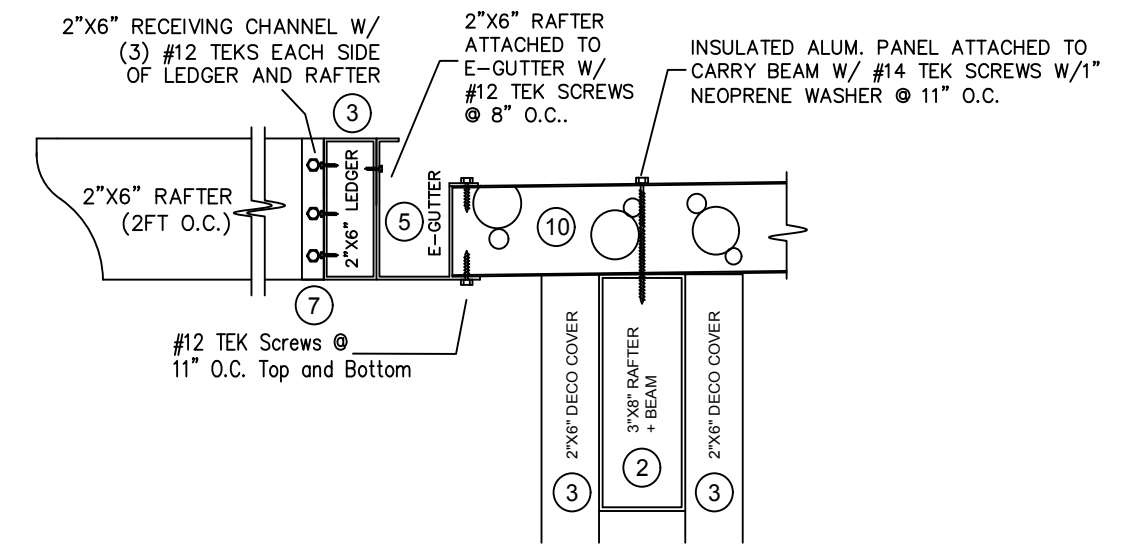

**DECO RAFTER DETAIL**

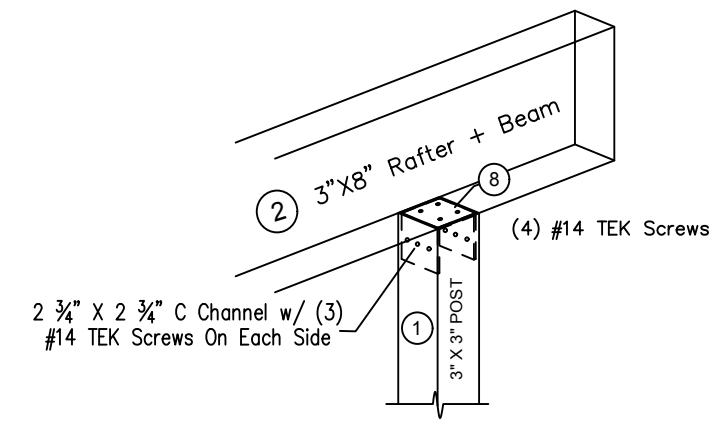

**POST TO BEAM CONNECTION**

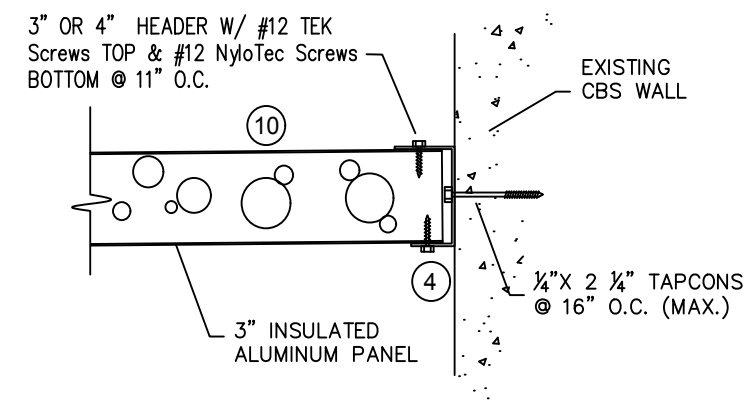

**INSULATED PANEL TO CBS WALL**

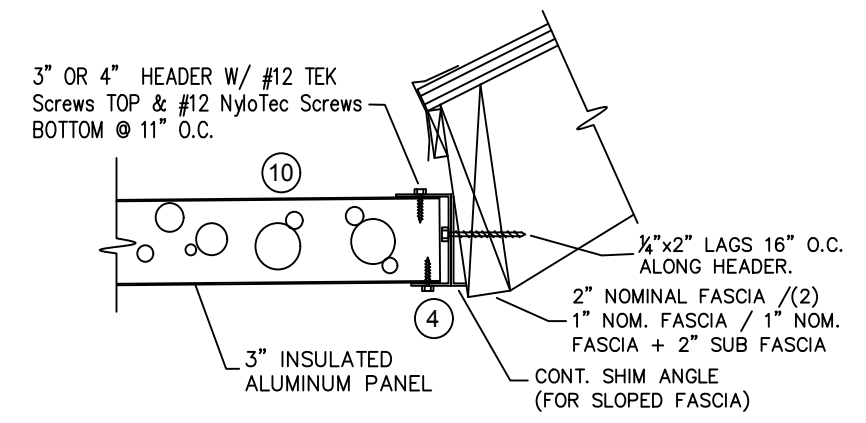

**INSULATED PANEL TO FASCIA**

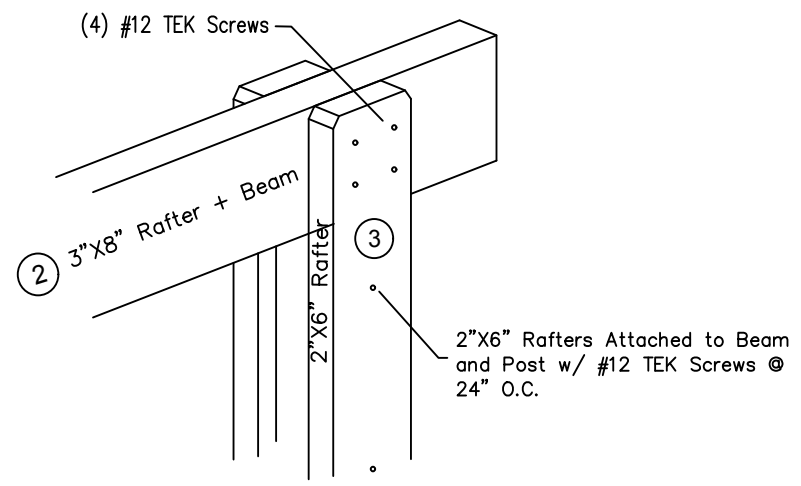

**POST COVER CONNECTION**

**CONNECTIONS**

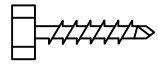

**#12x1" TEK Screws**

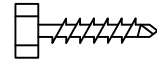

**#14x1" TEK Screws**

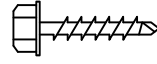

**#12x1" NyloTec Screws**



**Caulking  
(White or Bronze)**

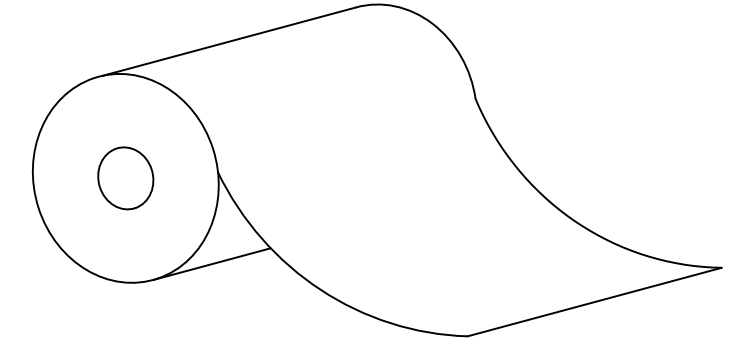

**Peel & Seal**

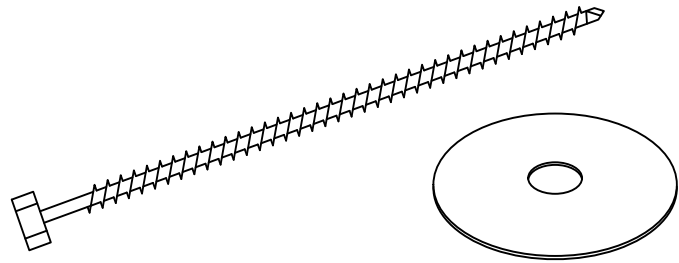

**#14x5" TEK Screws w/  
Neoprene Washer**

FOR 3" INSULATED PANELS

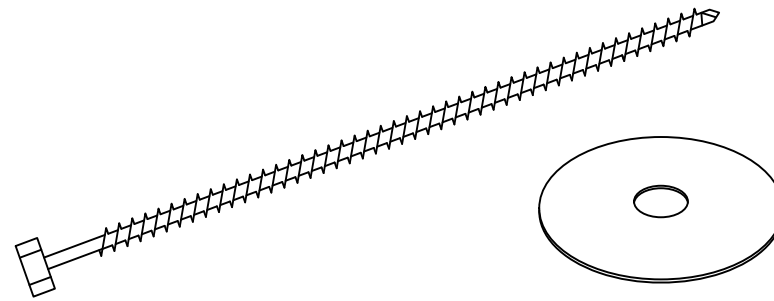

**#14x6" TEK Screws w/  
Neoprene Washer**

FOR 4" INSULATED PANELS

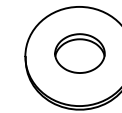

**3/8" Washers**

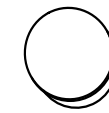

**3/8" Plastic Caps**



**1/4"x2 1/4" Tapcon Screws**

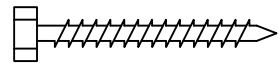

**1/4"x2" Lag Screws**



**3/8"x3 1/2" Hex Bolts**

**HARDWARE**